

# Fire Protection for Structural Steel

Interchar<sup>®</sup>

Chartek<sup>®</sup>



**AkzoNobel**

# State of the art fire protection from International Paint

Fire protection is an important decision that should be carefully considered at an early design stage. The budget and construction schedule can be heavily impacted if the fire protection is considered too late or the options are not fully understood.

For over 35 years our Interchar and Chartek products have provided anti-corrosive and aesthetic fire protection for steel structures in markets including infrastructure, power, oil and gas, chemical, mining and bridges.

All over the world, we are working with customers from the design phase, to application and through to construction ensuring specification and code compliance.

Before selecting the fire protection option, the complete installed system should be considered such as total material and application cost, material compatibility, impact on construction schedule and lifecycle costs including maintenance.



## Why do materials require fire protection?

Most materials are not inherently resistant to the effects of fire and therefore require fire protection. Steel is the most prominently protected material but protection can include other materials such as aluminium and plastics.

Whatever the material to be protected from the effects of a fire the principles are the same, namely, to prevent the rise in temperature of the protected substrate to maintain its structural integrity.

Put simply fire protection gives you TIME to escape and TIME to extinguish the fire reducing damage to the asset and its surroundings.

Due to the different nature of fire types and standards the correct product selection is critical.





# What type of fire protection do different structures require?

## Built environment

Usually cellulosic, but sometimes hydrocarbon fire protection for architectural applications including external exposed (such as exoskeleton), internal structural members and escape routes for:

- Tall Buildings
- Commercial Buildings
- Airports and transportation hubs
- Bridges
- Stadiums and sports arenas



## Industrial installations

Hydrocarbon, cellulosic and sometimes jet fire protection for areas such as members, vessels, pipework and equipment located on:

- Chemical plants
- Nuclear power plants
- Petrochemical plants
- Refineries
- LPG/LNG processing facilities
- Oil sands plants



## Offshore installations

Hydrocarbon and jet fire protection for areas such as structural steel, fire and blast walls, under decks and piping found on:

- Fixed oil and gas platforms
- Offshore LNG terminals
- Floating oil and gas production and storage vessels (eg FPSOs)



Courtesy of Bluewater

# Why choose our products?

## Interchar Acrylic

- Water and solvent borne technologies
- Excellent aesthetics
- Global approvals
- Competitive loadings

## Interchar Epoxy

- 100% volume solids (almost zero VOCs - volatile organic compounds)
- Enhanced mechanical properties
- Excellent external durability
- Offsite application allowing faster construction

## Chartek

- Most widely used epoxy passive fire protection (PFP)
- Low density material means low installed weight
- Excellent long term corrosion protection
- Extensive certification and track record
- 100% volume solids
- Protection against hydrocarbon and jet fires

## Media TIC Building, Barcelona, Spain

Situated in the centre of Barcelona, the Media-TIC building is a futuristic mixed use development, utilized by those within the technology industry to share knowledge, ideas and training. Originally a warehouse, it was redeveloped and thanks to a ground breaking exterior facade and various other energy efficiency measures, the structure boasts close to net-zero carbon emissions.

To protect the structural integrity of this valuable asset in case of fire and to meet the rigorous fire safety standards placed on modern buildings of this type, Interchar 404 intumescent fire protection was chosen for its excellent aesthetics whilst still providing optimum passive fire protection for the structure. Interchar 404 carries the CE mark, demonstrating it has been tested extensively to meet the highest fire protection industry standards across Europe.

## The System

Interchar 404

## Did you know?

The Media-TIC building was awarded the prestigious title of 'Building of the Year' Award at the World Architectural Festival 2011 for its innovative approach to CO2 reduction, as well as for its pro-active approach in leading sustainable design for the future.

# Track Records

## Track Record **Melbourne Airport** | Australia



**System** Intercure® 200  
Interchar 963  
Interthane® 870  
  
Intercure 200  
Interchar 1120

Interchar was utilised to provide 60 minutes fire protection during the expansion of Melbourne Airport. The properties of Interchar allowed the steel to be coated offsite and delivered to site already fire protected saving valuable time during construction and ensuring a robust quality control programme.

## Track Record **Infosys Software Park** | India



**System** Interseal® 670HS  
Interchar 963  
Intersheen® 579

Indian firm Infosys employs over 80,000 people worldwide and established a new office in 2005 located in Pune, India. This eye-catching building utilised Interchar fire protection to safeguard life and protect the structure from collapse in the event of fire.

## Track Record **Akpo FPSO** | West Africa



Photo © Total - Peter Livemore

**System** Interzinc® 52  
Intergard® 269  
Chartek 7  
Intergard 475HS  
Interthane 990

Chartek 7 was selected for the Akpo FPSO project, one of the biggest FPSOs in the world, because of its failure free track record and ease of application.

## Track Record **Freeport LNG** | USA



**System** Intergard 251  
Chartek 1709  
Interthane 990

Chartek 1709 was used on the Freeport LNG terminal in the USA due to its suitability for off-site application and long term maintenance free performance.

# Onsite or offsite application - what is the optimal solution for your project?

Our fire protection products are suitable for both onsite and offsite application but offsite application can deliver the benefits listed below.

## Time Saving

- Reduction in site disruption
- Fire protection removed from critical path meaning quicker construction

## Quality

- Improved quality control
- Reduced weather sensitivity

## HS&E

- Reduced site solvent emissions
- Improved safety onsite due to fewer trades

## Reduced Cost

- Quicker return on investment from faster construction



Proven long term aesthetics, corrosion and fire protection is not only about the technology but the expertise and experience of the supplier who delivers the right product for your project needs.

Once the correct product is specified you must also consider if the advice and support given before, during and after the project is professional and accurate.



Our dedicated fire protection technical service team supports a global network of qualified applicators with:

- Recommendations and practical experience
- Quality control procedures
- Application guidelines
- Advice on inspection and future maintenance

## Common product issues with cementitious passive fire protection:

- Aesthetically not very appealing
- Offers NO corrosion protection which can cause detachment and hidden corrosion under fire protection
- Water ingress can be an issue even when topcoated increasing the risk of corrosion and maintenance costs
- Significant increased weight and load on structures
- Poor durability including weathering and mechanical properties
- Very slow to dry so can delay construction
- Application can be slowed by weather conditions



# Research and Development Facilities

Fire protection materials are safety critical products, their primary function is to protect lives and assets. We believe having our own fire testing facilities to carry out research and development is an absolute necessity.



Felling Fire Protection Laboratory

At International Paint we are committed to establishing new technology platforms to support product development. Our Fire Protection Centre of Excellence includes a state-of-the-art laboratory, as well as research, development, application and testing capabilities. This facility aims to promote technical leadership and deliver best in class products in addition to supporting our existing range. We strive to develop innovative, safe and robust fire protection systems, tested to align with the needs our clients.

The facility contains two screening furnaces, two 1.5m<sup>3</sup> furnaces and a large 4m x 3m x 2m floor furnace with the capability of testing loaded beams. It also houses fire protection development labs, dedicated application facilities and environmentally controlled conditioning areas.

Up to ten fire tests per day can be accommodated within the new building, including bespoke fire testing to suit customers' needs.

The Fire Protection Centre of Excellence complements our Fire Protection capabilities, which include structural and fire engineering experience, estimation expertise and anti-corrosion performance knowledge.

By integrating into design contract chains and working alongside owners, architects, design engineers and steel fabricators, we can draw on our global resources to offer a much broader fire protection service than just coatings supply.

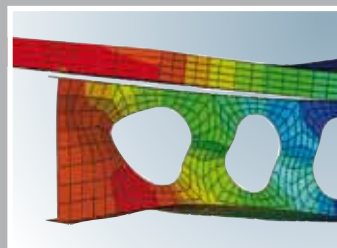

# Choose International Paint

- Part of AkzoNobel, the world's largest coatings company, whose brands include Chartek, International, Sikkens, Devoe and Interpon
- Over 35 years of fire protection experience
- Ability to supply high quality products and services to projects anywhere in the world
- Own global product manufacturing and supply of complete coating system
- Global network allows full support of multinational project needs
- Consistent quality from raw materials to product selection to manufacture and technical support
- Large product range independently tested to meet your project needs

Interchar and Chartek are vigorously tested in-house and by third parties to deliver you and your customer advanced technology that you can rely on.

# Our Complete System

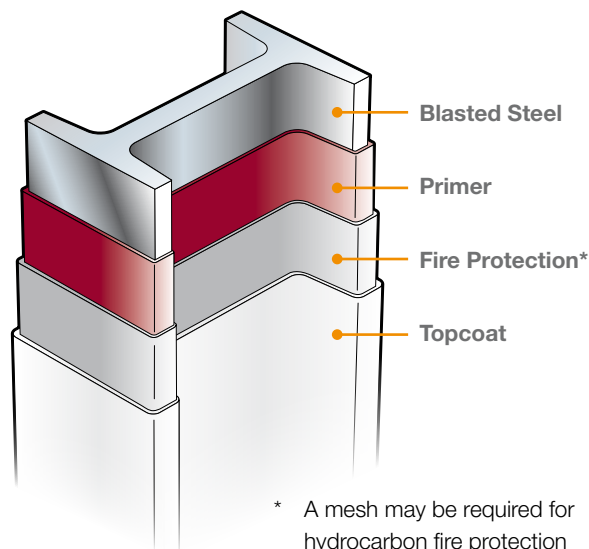

[www.international-pc.com](http://www.international-pc.com)  
[protectivecoatings@akzonobel.com](mailto:protectivecoatings@akzonobel.com)

✘ and **International** and all product names mentioned in this publication are trademarks of, or licensed to, AkzoNobel. © AKZONOBEL 2012.

International Protective Coatings has used its best endeavours to ensure that the information contained in this publication is correct at the time of printing. Please contact your local International Protective Coatings representative if you have any questions.

Unless otherwise agreed by us in writing, any contact to purchase products referred to in this brochure and any advice which we give in connection with the supply of products are subject to our standard conditions of sale and the provisions of the relevant product data sheet.